

HIGH SPIN HYGIENIC BARRIER WASHER EXTRACTORS



**MXB
RANGE**

MXB360 MXB500 MXB700

36KG 50KG 70KG
79LB 110LB 154LB



FEATURES

- Freestanding, high spin
- Oversized frame, bearings and drum
- Large drain valves (2 x Ø 76 mm)
- Easy access to all parts
- Frequency controlled motor
- Large door opening for easy loading and unloading
- Perforated lifting ribs: more mechanical action, lower water consumption
- USB & RS485 plug
- Soap dispenser with 5 removable compartments
- Designed with focus on ergonomics
- Patented Cascade Drum

OPTIONS

- Liquid soap pumps
- Insulation for energy and noise reduction
- Version without soap hopper
- Drain valve for water recycling
- Water sample tap
- Second display (located on the clean side)
- Lateral drain
- End of cycle extra signaling (orange light + siren)
- End of cycle extra signaling (traffic light + siren)
- Optiload® - Weighing system
- Third water inlet
- Air-operated water inlets

XCONTROL FLEX PLUS PLATFORM

- 7", full color touch screen display with swipe function: very intuitive for users
- User-friendly screen with operating instructions built in as part of the control
- Complete control content available in 34 languages
- Wireless communication enabling programming
- Automated service reminders remind users to maintenance tasks
- Combine with Trace-Tech™ and i-Trace laundry management softwares for a perfect control of your laundry installation



XControl FLEX PLUS approach, program, and cycle screens



GET AHEAD IN LAUNDRY

*Consult your sales representative for availability

TYPE		MXB360	MXB500	MXB700
CAPACITY				
Drum volume	l	360	500	700
Capacity 1:10	kg/lb	36/79	50/110	70/154
Capacity 1:9	kg/lb	40/88	55,5/122	78/172
Drum diameter			775	
Drum depth	mm	764	1060	1484
Drum type			Cascade	
Number of drums		1	1	2
Number of loading doors		1	1	2
Number of unloading doors		1	1	2
MOTOR				
Power	kW	4		7,5
DRUM SPEED				
Wash speed	rpm		41	
Extraction speed	rpm		900	
G-Factor			350	
PROGRAMMER				
XControl FLEX PLUS			standard	
CABINET				
Door opening angle			155	
HEATING				
100% hot water	°C		90	
100% electrical	kW	36	48	60
Steam high pressure	bar		3-8	
CONNECTION				
Electrical			3x 200-240V 50/60Hz 3x 380-415V 50/60Hz 3x 440-480V 50/60Hz	
Water inlet	in		3x 1"	
Steam inlet	in		3/4"	
Drain diameter	in		2x 3"	
DIMENSIONS				
H×W×D	mm	1700 x 1270 x 980	1700 x 1566 x 980	1700 x 2032 x 980
Net weight	kg	960	1130	1310
TRANSPORT DATA				
Packed H×W×D	mm	2005x1530x1255	2005x1830x1255	2005x2290x1255
Gross weight	kg	1090	1280	1470

36 / 50 kg

70 kg

36, 50, 70 kg

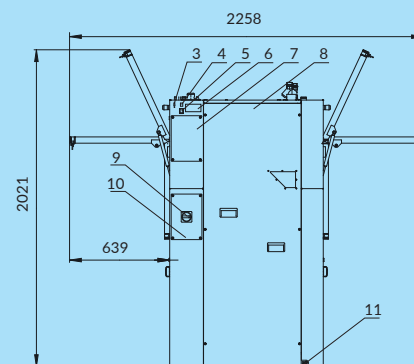
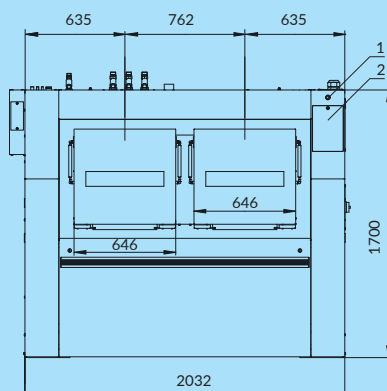
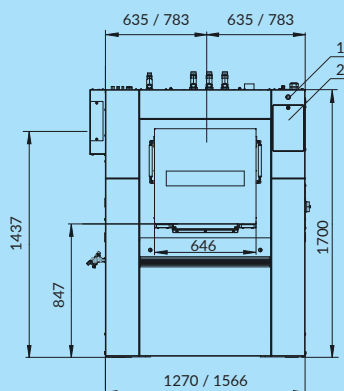

- 1 Emergency stop
- 2 Control panel
- 3 USB Port
- 4 PC Programming Connection

- 5 Switch: Steam / Electric Heating
- 6 Serial Plate
- 7 Electrical Signals Liquid Soap Cover
- 8 Electrical Components with Frequency Inverter Cover

- 9 Main Switch Cover
- 10 Main Switch
- 11 Equipotential Bounding Terminal